

Specifications

Spider Crane

The UNIC spider crane has a safe load indicator, the URW- 506's working limitation device allows the operator to pre-de- fine the working area giving greater control and safety in sensitive areas. On approaching these limits, function speeds are reduced and an audible alarm is given before operation stops.

The URW-506 Mini Crane offers an optimal combination of working flexibility and heavy lifting power. The crane is capable of lifting 3 tonnes at 3.4m or up to 4 tonnes with an optional 5 fall hook block.

Searcher Hook

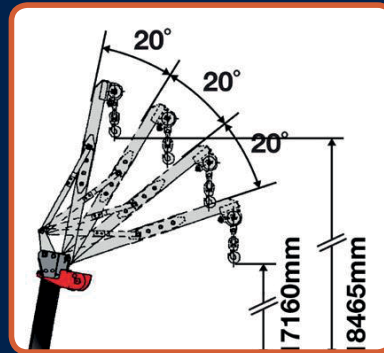

Maximum Load
350kg - 700kg (radius rated)

Fly Jib

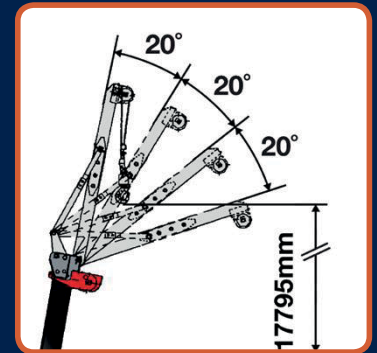

Maximum Load
350kg - 700kg (angle rated)

Crane Capacity	3.0t x 3.4m
Max Working Radius	15.52m
Max Lifting Height	16m (17.79m with fly jib, 18.46m with fixed hook)
Rope Length	20.52m (4 fall), 42.54m, (2 fall), 86.57m (1 fall)
Dimensions	4370mm (l) x 1400mm (w) x 2035mm (h)
Weight	4840kg
Hook Speed	17m/mim (with 4 layers and 4 falls)
Telescopic Boom	6 section, Length 3.93 – 15.71m, Speed 11.78m/35secs
Derricking Angle/Speed	0-80° / 18 seconds

Slewing Angle/Speed	360° (continuous) 2.5min rpm
Traction Drive	Hydrostatic 2-speed, stepless forward & reverse
Speed	0 – 3km/h
Gradability	23° 942%
Track Ground Length	1750mm
Track Ground Pressure	45.1kN/m2 (0.46kg/cm2)
Track Width	300mm
Engine	Mitsubishi / Yanmar
Fuel	Diesel
Max Output	18kW (24.5PS) / 2100min rpm
Starting Method	Electric
Tank Capacity	40 litres

Standard Equipment

Computer Controlled Moment Limiter (safe load indicator)
Radio Remote Control
Overwinding Alarm
Computer Controlled Intelligent Voice Warning System
Multi-function operation by Radio Remote Control

Intelligent Throttle Activation
Automatic Hook Stow
Overload Warning Alarms
Overload Warning Lamps
Working Area Limitation

WIND SPEED Do not operate crane when wind speed exceeds 10m/sec (36 kph or 22 mph).



LEASK MARINE

International Marine Contractors

Spider Crane

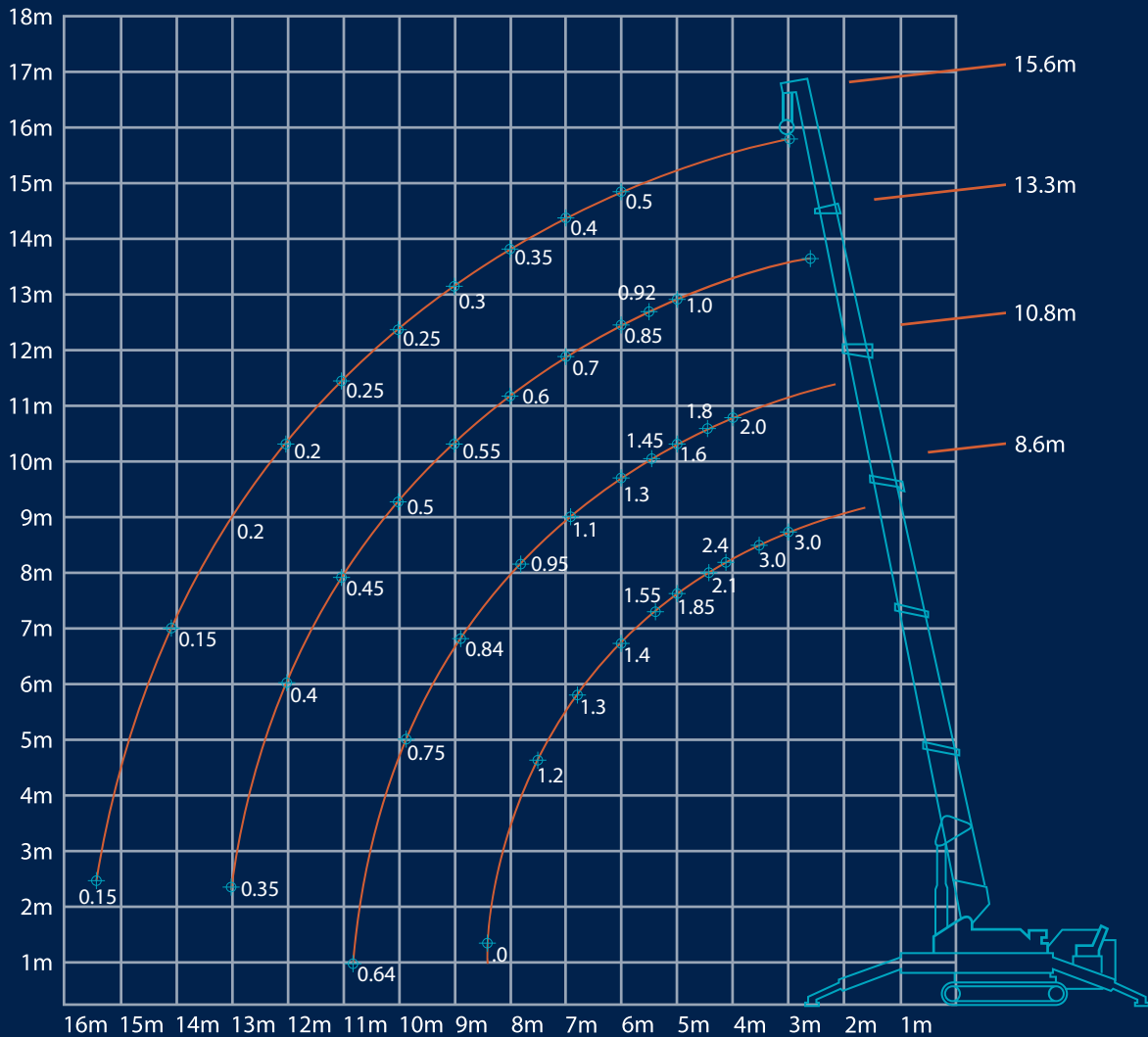
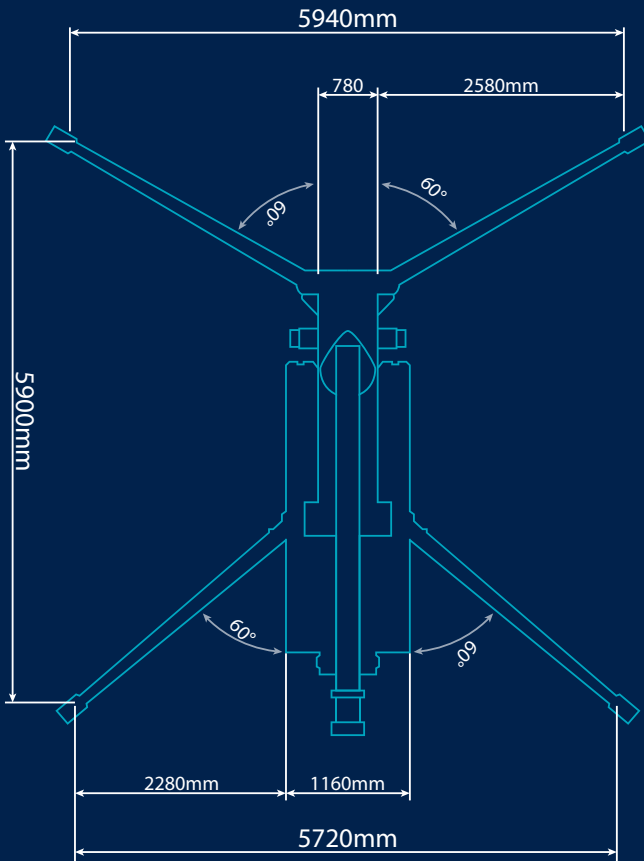

+44 (0) 1856 874725

info@leaskmarine.co.uk

www.leaskmarine.com