



## Specifications

## 10 Ton Spooling Machine

### General

Machine Number ..... LME500  
 Date Of Manufacture ..... 01/10/2017  
 Description ..... 10 Tonne Cable Spooler  
 Purpose ..... Controlled Deployment/  
 Recovery Cable Products

Set Up ..... 415v Hydraulic Driven  
 Power Unit  
 C/W 15m Deck Hoses  
 Drum RPM ..... 2.5rpm (45lpm Pump)  
 Maximum Reel Weight ..... 20 Tonne Including Reel  
 10.5 Tonne Core Pull  
 @ 1200mm Diameter  
 Drum Centre

### Overall Dimensions

Length ..... 4300mm  
 Width ..... 2370mm  
 Height ..... 3000mm  
 Shaft Hole Diameter ..... Min 105mm  
 Support Shaft ..... Ø100mm  
 Maximum Reel Diameter ..... 2700mm  
 Maximum Reel Width ..... 2500mm  
 Spooler Weight ..... 4 Tonne

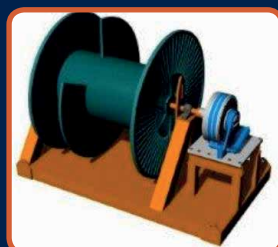
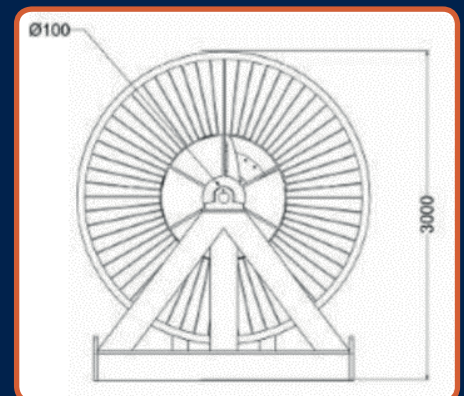
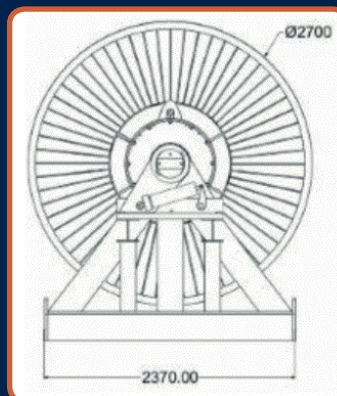
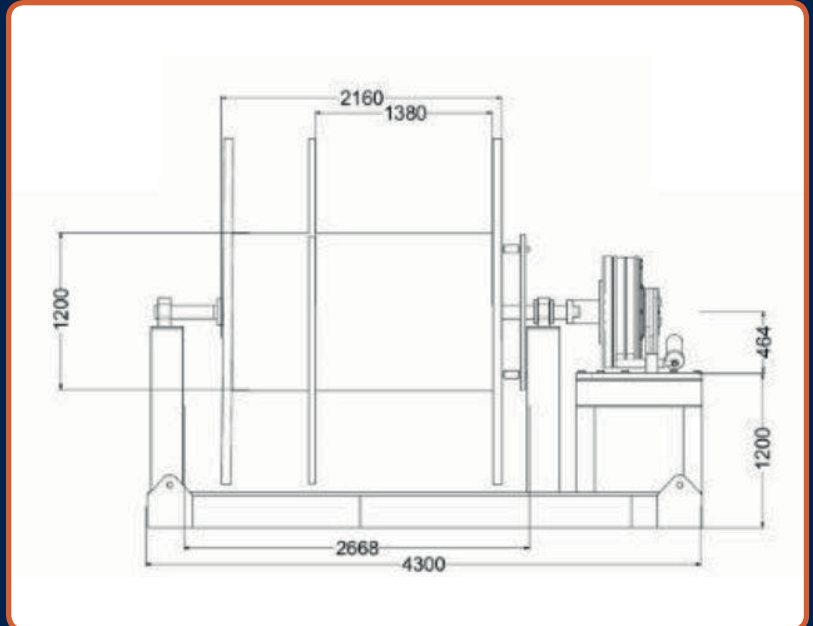



International Marine Contractors

# 10 Ton Spooling Machine

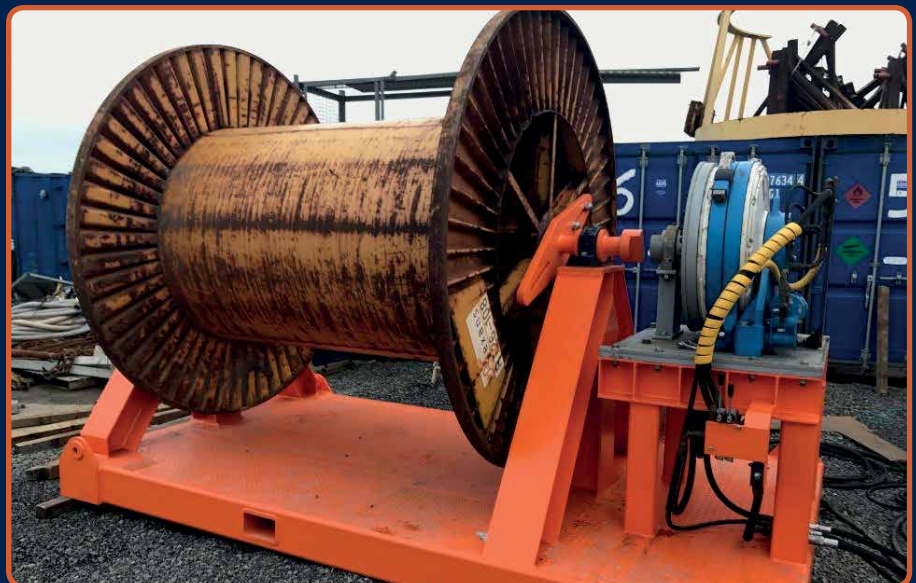

+44 (0) 1856 874725  
info@leaskmarine.co.uk    www.leaskmarine.com